

## MODEL ICM8 – COMMUNICATION GATEWAY



- COMMUNICATION GATEWAY FOR RED LION PRODUCTS
- PROTOCOLS AVAILABLE: RS232, RS485 AND ETHERNET
- PROGRAMMABLE VIA CRIMSON SOFTWARE
- USB PROGRAMMING PORT
- EXTENSIVE BUILT-IN DRIVER LIST ALLOWS EASY DATA MAPPING TO PLCs, PCs, AND SCADA SYSTEMS
- 10 BASE-T/100 BASE-TX ETHERNET CONNECTION CAN CONNECT TO AN UNLIMITED NUMBER OF DEVICES VIA FOUR PROTOCOLS SIMULTANEOUSLY

### GENERAL DESCRIPTION

The ICM8 is designed to act as a communication gateway offering multiple protocol conversion for any Red Lion Product. With two serial ports (one RS232 and one RS485) and a 10 Base-T/100 Ethernet Port, the unit performs protocol conversion, allowing disparate devices to communicate seamlessly with one another. Programming the unit can be accomplished via the RS232 or the USB Port using Crimson Software. It is important to note that this device is designed to function with Red Lion Product and will not offer protocol conversion if a Red Lion Products is not connected to at least one of the serial ports.

The ICM8'S DIN rail mounting saves time and panel space and snaps easily onto standard top hat (T) profile DIN rail.

### SOFTWARE

The ICM8 is programmed with Windows® compatible Crimson 2.0 software. The software is an easy to use graphical interface which can be purchased as part of a kit that includes a manual and cables, or downloaded free of charge from www.redlion.net.

### SAFETY SUMMARY

All safety related regulations, local codes and instructions that appear in the manual or on equipment must be observed to ensure personal safety and to prevent damage to either the instrument or equipment connected to it. If equipment is used in a manner not specified by the manufacturer, the protection provided by the equipment may be impaired.

Do not use the controller to directly command motors, valves, or other actuators not equipped with safeguards. To do so can be potentially harmful to persons or equipment in the event of a fault to the controller. An independent and redundant temperature limit indicator with alarm outputs is strongly recommended.

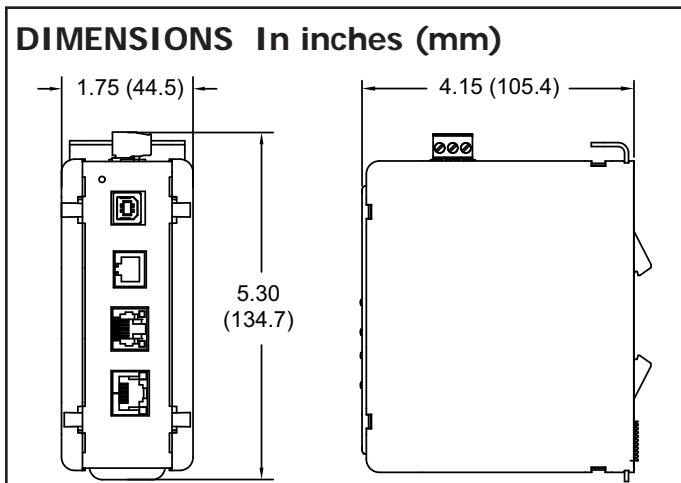

### SPECIFICATIONS

1. **POWER:** 24 VDC ± 10% 200 mA max. Must use a Class 2 or SELV rated power supply.
2. **COMMUNICATIONS:**
  - USB/PG Port:** Adheres to USB specification 1.1. Device only using Type B connection.
  - Serial Ports:** Format and Baud Rates for each port are individually software programmable up to 115,200 baud.
  - RS232/PG Port:** RS232 port via RJ12
  - COMMS Ports:** RS485 port via RJ11
  - Ethernet Port:** 10 BASE-T / 100 BASE-TX
3. **LEDs:**
  - STX – Status LED indicates condition of ICM8.
  - TX/RX – Transmit/Receive LEDs show serial activity.
  - Ethernet – Link and activity LEDs.
4. **MEMORY:**
  - On-board User Memory: 4 Mbytes of non-volatile Flash memory.
  - On-board SDRAM: 2 Mbytes

**5. CERTIFICATIONS AND COMPLIANCES:**

**SAFETY**

IEC 1010-1, EN 61010-1: Safety requirements for electrical equipment for measurement, control, and laboratory use, Part 1.

**ELECTROMAGNETIC COMPATIBILITY**

Emissions and Immunity to EN 61326: Electrical Equipment for Measurement, Control and Laboratory use.

**Immunity to Industrial Locations:**

Electrostatic discharge	EN 61000-4-2	Criterion B <sup>3</sup> 4 kV contact discharge 8 kV air discharge
Electromagnetic RF fields	EN 61000-4-3	Criterion A 10 V/m
Fast transients (burst)	EN 61000-4-4	Criterion B 2 kV power 1 kV signal
Surge	EN 61000-4-5	Criterion A 1kV L-L, 2 kV L&N-E power
RF conducted interference	EN 61000-4-6	Criterion A 3 V/rms

**Emissions:**

Emissions	EN 55011	Class A
-----------	----------	---------

*Notes:*

1. *Criterion A: Normal operation within specified limits.*
2. *Criterion B: Temporary loss of performance from which the unit self-recovers.*
3. *This device was designed for installation in an enclosure. To avoid electrostatic discharge to the unit in environments with static levels above 4 kV precautions should be taken when the device is mounted outside an enclosure. When working in an enclosure (ex. making adjustments, setting switches etc.) typical anti-static precautions should be observed before touching the unit.*

**6. ENVIRONMENTAL CONDITIONS:**

Operating Temperature Range: 0 to 50°C  
 Storage Temperature Range: -30 to +70°C  
 Operating and Storage Humidity: 80% max relative humidity, non-condensing, from 0 to 50°C  
 Altitude: Up to 2000 meters

7. **CONSTRUCTION:** Case body is black high impact plastic and stainless steel. Installation Category I, Pollution Degree 2.
8. **POWER CONNECTION:** Removable wire clamp screw terminal block.  
 Wire Gage Capacity: 24 AWG to 12 AWG  
 Torque: 4.45 to 5.34 in/lb (0.5 to 0.6 N-m)
9. **MOUNTING:** Snaps onto standard DIN style top hat (T) profile mounting rails according to EN50022 -35 x 7.5 and -35 x 15.
10. **WEIGHT:** 12.3 oz (348g)

**HARDWARE  
INSTALLATION**

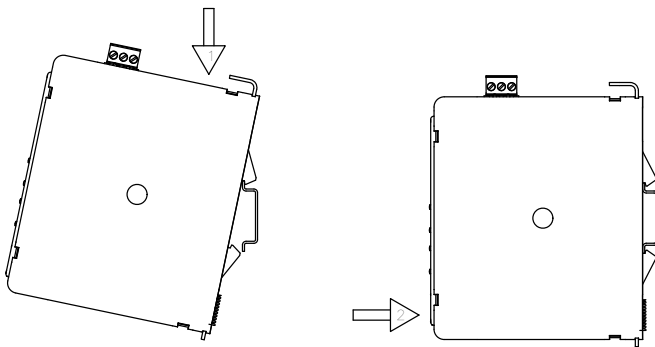

**Figure 1 - Attach ICM8 To DIN Rail**

**POWER SUPPLY REQUIREMENTS**

It is very important that the power supply is mounted correctly if the unit is to operate reliably. Please take care to observe the following points:

- The power supply must be mounted close to the unit, with usually not more than 6 feet (1.8 m) of cable between the supply and the ICM8. Ideally, the shortest length possible should be used.
- The wire used to connect the ICM8's power supply should be at least 22-gage wire. If a longer cable run is used, a heavier gage wire should be used. The routing of the cable should be kept away from large contactors, inverters, and other devices which may generate significant electrical noise.
- A power supply with a Class 2 or SELV rating is to be used. A Class 2 or SELV power supply provides isolation to accessible circuits from hazardous voltage levels generated by a mains power supply due to single faults. SELV is an acronym for "safety extra-low voltage." Safety extra-low voltage circuits shall exhibit voltages safe to touch both under normal operating conditions and after a single fault, such as a breakdown of a layer of basic insulation or after the failure of a single component has occurred.

# EMC INSTALLATION GUIDELINES

Although Red Lion Controls Products are designed with a high degree of immunity to Electromagnetic Interference (EMI), proper installation and wiring methods must be followed to ensure compatibility in each application. The type of the electrical noise, source or coupling method into a unit may be different for various installations. Cable length, routing, and shield termination are very important and can mean the difference between a successful or troublesome installation. Listed are some EMI guidelines for a successful installation in an industrial environment.

1. To reduce the chance of noise spikes entering the unit via the power lines, connections should be made to a clean source. Connecting to circuits that also power loads such as contactors, relays, motors, solenoids etc. should be avoided.
2. The unit should be mounted in a metal enclosure, which is properly connected to protective earth.
3. Use shielded (screened) cables for all Signal and Control inputs. The shield (screen) pigtail connection should be made as short as possible. The connection point for the shield depends somewhat upon the application. Listed below are the recommended methods of connecting the shield, in order of their effectiveness.
  - a. Connect the shield to earth ground (protective earth) at one end where the unit is mounted.
  - b. Connect the shield to earth ground at both ends of the cable, usually when the noise source frequency is over 1 MHz.
  - c. Connect the shield to common of the Data Station and leave the other end of the shield unconnected and insulated from earth ground.

4. Never run Signal or Control cables in the same conduit or raceway with AC power lines, conductors feeding motors, solenoids, SCR controls, and heaters, etc. The cables should be run through metal conduit that is properly grounded. This is especially useful in applications where cable runs are long and portable two-way radios are used in close proximity or if the installation is near a commercial radio transmitter. Also, Signal or Control cables within an enclosure should be routed as far away as possible from contactors, control relays, transformers, and other noisy components.
5. Long cable runs are more susceptible to EMI pickup than short cable runs. Therefore, keep cable runs as short as possible.
6. In extremely high EMI environments, the use of external EMI suppression devices is effective. The following EMI suppression devices (or equivalent) are recommended:

- Ferrite Suppression Cores for signal and control cables:
- Fair-Rite part number 0443167251 (RLC part number FCOR0000)
  - TDK part number ZCAT3035-1330A
  - Steward part number 28B2029-0A0
- Line Filters for input power cables:
- Schaffner part number FN610-1/07 (RLC part number LFIL0000)
  - Schaffner part number FN670-1.8/07
  - Corcom part number 1 VR3

Visit RLC's web site at [www.redlion.net](http://www.redlion.net) for more information on EMI guidelines, Safety and CE issues as they relate to Red Lion Controls products.

## WIRING

### POWER CONNECTION

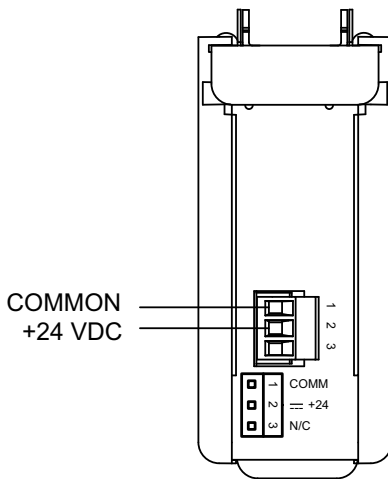

### PROGRAMMING PORTS

#### USB/PG

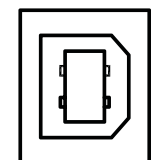

#### RS232/PG

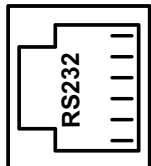

CTS  
Rx  
COMM  
COMM  
Tx  
RTS

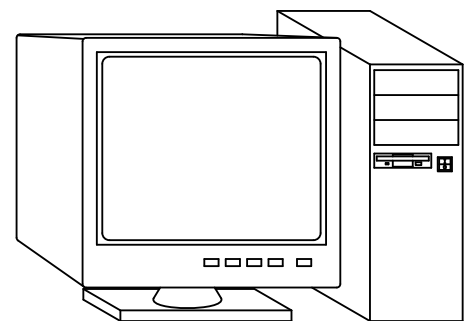
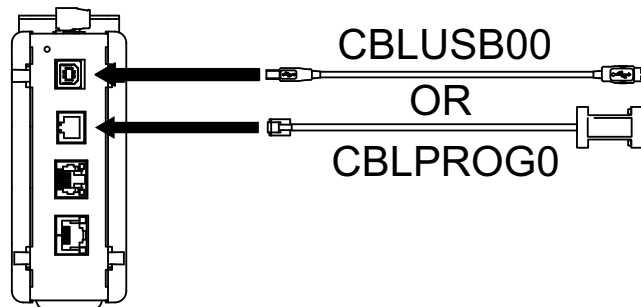

# COMMUNICATION PORTS

## RS232/PG

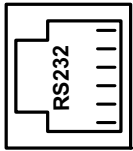

CTS  
Rx  
COMM  
Tx  
RTS

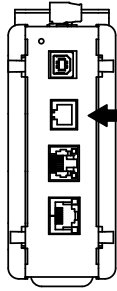

CBLPROG0

OR

CBLxxxxx\*

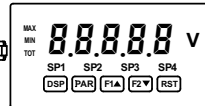
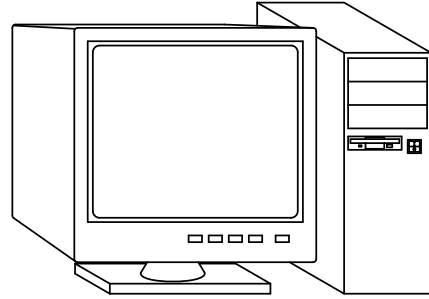

\* Use appropriate communications cable.  
See Ordering Information for descriptions of the available cables.

## RS485

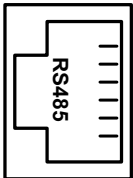

NC (PIN 1)  
NC  
COMM  
A (+)  
B (-)  
NC (PIN 6)

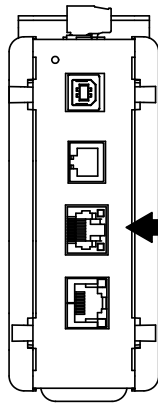

CBLxxxxx\*

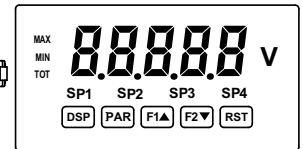

## PORT 3 - ETHERNET CONNECTION

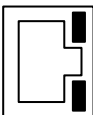

GREEN/ORANGE LED

AMBER LED

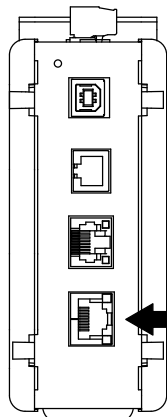

Standard Ethernet cable

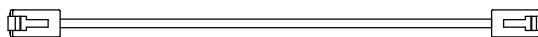

# ICM8 PORT PIN OUTS

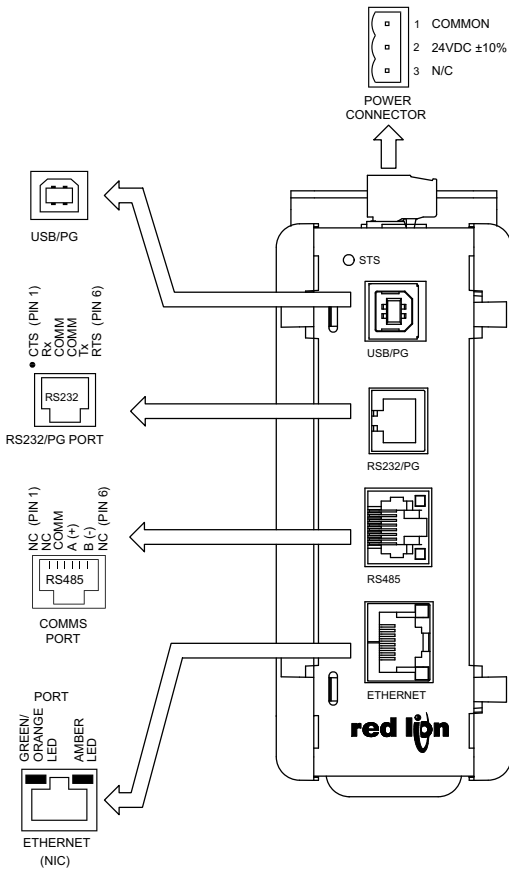

## TROUBLESHOOTING

1. This module is designed to operate with Red Lion panel meters only. Please make sure a Red Lion product is connected to either one of the two serial ports for the gateway to be active.
2. The Ethernet port is equipped with data LEDs. If they are blinking, the converter is active and the data is available at the port. Please verify the receiving equipment is properly programmed.
3. If for any reason you have trouble operating, connecting, or simply have questions concerning your new ICM8, contact Red Lion's technical support. For contact information, refer to the back page of this bulletin for phone and fax numbers.

EMAIL: [techsupport@redlion.net](mailto:techsupport@redlion.net)  
 Web Site: <http://www.redlion.net>

# COMMUNICATING WITH THE ICM8

## CONFIGURING THE ICM8

The ICM8 is configured using Crimson 2.0 software. Crimson 2.0 is available as a free download from Red Lion's website, or it can be ordered on CD. Updates to Crimson 2.0 for new features and drivers are posted on the website as they become available. By configuring the ICM8 using the latest version of Crimson 2.0, you are assured that your unit has the most up to date feature set. Crimson 2.0 software can configure the ICM8 through the RS232/PG port or USB/PG port. The USB/PG port is connected using a standard USB cable with a Type B connector.

The driver needed to use the USB port will be installed with Crimson 2.0. The RS232/PG port uses a programming cable made by Red Lion to connect to the DB9 COM port of your computer. If making your own cable, refer to the "ICM8 Port Pin Outs" for wiring information.

## CABLES AND DRIVERS

Red Lion has a wide range of cables and drivers for use with many different communication types. A list of these drivers and cables along with pin outs is available from Red Lion's website. New cables and drivers are added on a regular basis. If making your own cable, refer to the "ICM8 Port Pin Outs" for wiring information.

## ETHERNET COMMUNICATIONS

Ethernet communications can be established at either 10 BASE-T or 100 BASE-TX. The Crimson 2.0 manual contains additional information on Ethernet communications.

## RS232 PORTS

The ICM8 has one RS232 port. The port can be used for programming or communications.

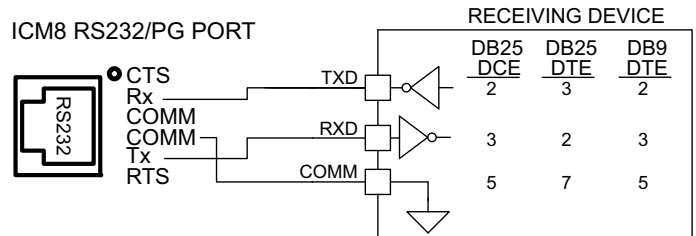

## RS485 PORT

The ICM8 has one RS485 port.

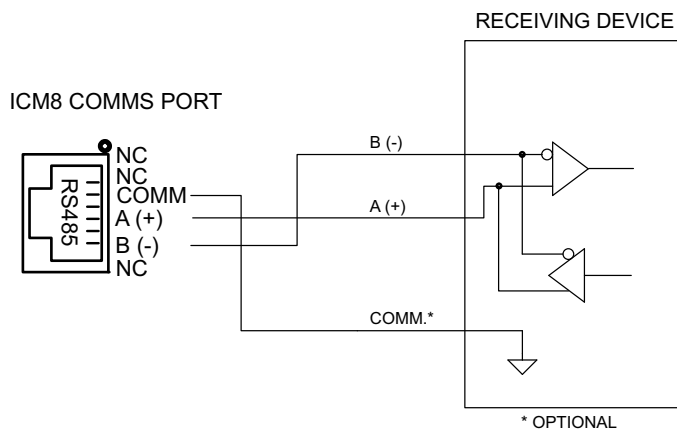

*Note: All Red Lion devices connect A to A and B to B, except for Paradigm devices. Refer to [www.redlion.net](http://www.redlion.net) for additional information.*

## LEDS

### STS – STATUS LED

The green Status LED provides information regarding the state of the ICM8. This includes indication of the various stages of the start-up routine (power-up), and any errors that may occur.

### Startup Routing

	INDICATION
Rapidly Flashing	ICM8 is currently running the boot loader and/or being flash upgraded by Crimson
Steady	ICM8 is operating properly

### USER COMMUNICATION PORTS - TX/RX LEDES

LED	INDICATION
GREEN	Transmitting
RED	Receiving

### ETHERNET LEDES

LED	INDICATION
YELLOW (Solid)	Link Established
YELLOW (Flashing)	Network Activity
GREEN	10 BASE-T Communications
AMBER	100 BASE-T Communications

## ORDERING INFORMATION

MODEL NO.	DESCRIPTION	PART NUMBER
ICM8	Communication Gateway	ICM80000
PSDR	DIN Rail Power Supply	PSDRxxxx
SFCRM2	Crimson 2.0 <sup>2</sup> , Manual and Download Cable	SFCRM200
CBL	RS-232 Programming Cable	CBLPROG0
	USB Cable	CBLUSB00
	Communications Cables <sup>1</sup>	CBLxxxxx
DR	DIN Rail Mountable Adapter Products <sup>3</sup>	DRxxxxxx

<sup>1</sup> Contact your Red Lion distributor or visit our website for complete selection.

<sup>2</sup> Use this part number to purchase Crimson on CD with a printed manual, USB cable, and RS-232 cable. Otherwise, download free of charge from [www.redlion.net](http://www.redlion.net).

<sup>3</sup> Red Lion offers RJ modular jack adapters. Refer to the DR literature for complete details.

This page intentionally left blank

### **LIMITED WARRANTY**

The Company warrants the products it manufactures against defects in materials and workmanship for a period limited to two years from the date of shipment, provided the products have been stored, handled, installed, and used under proper conditions. The Company's liability under this limited warranty shall extend only to the repair or replacement of a defective product, at The Company's option. The Company disclaims all liability for any affirmation, promise or representation with respect to the products.

The customer agrees to hold Red Lion Controls harmless from, defend, and indemnify RLC against damages, claims, and expenses arising out of subsequent sales of RLC products or products containing components manufactured by RLC and based upon personal injuries, deaths, property damage, lost profits, and other matters which Buyer, its employees, or sub-contractors are or may be to any extent liable, including without limitation penalties imposed by the Consumer Product Safety Act (P.L. 92-573) and liability imposed upon any person pursuant to the Magnuson-Moss Warranty Act (P.L. 93-637), as now in effect or as amended hereafter.

No warranties expressed or implied are created with respect to The Company's products except those expressly contained herein. The Customer acknowledges the disclaimers and limitations contained herein and relies on no other warranties or affirmations.

Red Lion Controls  
Headquarters  
20 Willow Springs Circle  
York PA 17406  
Tel +1 (717) 767-6511  
Fax +1 (717) 764-0839

Red Lion Controls  
Europe  
Printerweg 10  
NL - 3821 AD Amersfoort  
Tel +31 (0) 334 723 225  
Fax +31 (0) 334 893 793

Red Lion Controls  
India  
54, Vishvas Tenement  
GST Road, New Ranip,  
Ahmedabad-382480 Gujarat, India  
Tel +91 987 954 0503  
Fax +91 79 275 31 350

Red Lion Controls  
China  
Unit 101, XinAn Plaza  
Building 13, No.99 Tianzhou Road  
ShangHai, P.R. China 200223  
Tel +86 21 6113-3688  
Fax +86 21 6113-3683