

MODELS ZBG AND ZBH STANDARD DUTY ENCODER (Replaces MODEL RRGB) MODEL ZHG HEAVY DUTY ENCODER (Replaces MODEL RRGH)

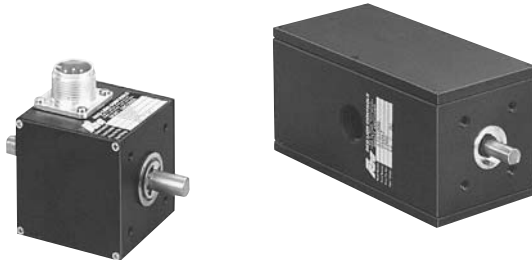

- **CURRENT SINK OUTPUTS**
- **HIGH PULSE PER REVOLUTION (PPR) RATES**
 Up to 1200 PPR for fine, high-resolution counting or precision speed measurement from slow shaft speeds.
- **QUADRATURE OUTPUT**
 For position measurement, bi-directional counting and in systems with backlash counting requirements.
- **AVAILABLE WITH MS AND M12 CONNECTORS**

MODEL ZBG and ZBH - FOR GENERAL INDUSTRIAL SERVICE (Replaces Model RRGB)

The units contain an L.E.D. light source and a photo sensor that scans a shaft-mounted, slotted disc. An internal pulse-shaping amplifier circuit delivers a rectangular pulse signal from the current sinking output in response to the passing slots as it rotates. They can be direct-coupled to a machine shaft by means of a flexible-bellows, spring, or rubber sleeve type coupling that allows for axial and radial misalignment. They can also be coupled with light instrument timing-belts. Timing-belt drives also allow convenient gear-up or gear-down speed ratio changes that can be useful for obtaining non-standard PPR rates.

MODEL ZHG - HEAVY-DUTY SEALED HOUSING (Replaces Model RRGH)

These heavy duty units feature a heavy cast aluminum housing with 1/4" thick aluminum cover plates and O-ring seals. Heavy duty bearings are double-sealed and allow radial shaft loading of 40 lbs (18 Kg).

A 1/2" (12.7 mm) NPT Conduit entry permits signal wiring to be run via flex-conduit to an internal terminal block. Electrical characteristics are identical to those for the Model ZBG. Terminal board markings correspond to the Pin-Out identification of the ZBG.

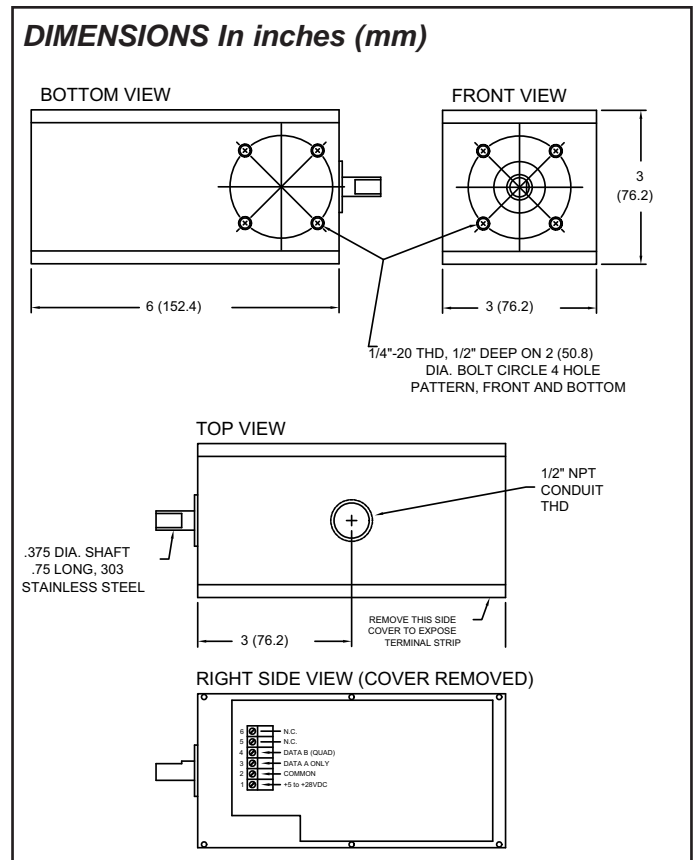
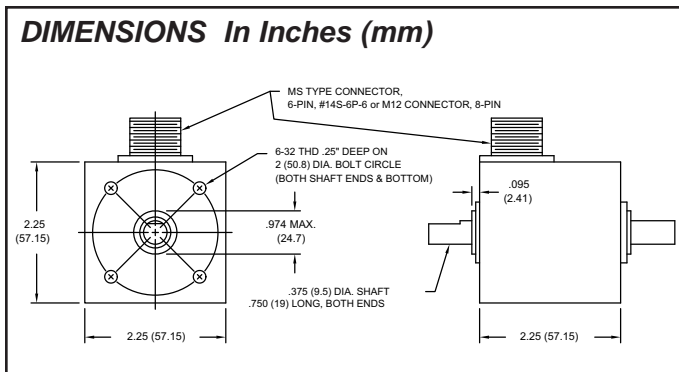

SPECIFICATIONS

ELECTRICAL SPECIFICATIONS

1. SUPPLY VOLTAGE:

- +4.75 to +28 VDC @ 80 mA max. from 0 °C to 85 °C
- +4.75 to +24 VDC @ 80 mA max. from 0 °C to 100 °C

2. OUTPUT: Current Sinking

ZBG and ZHG (Single Channel): 250 mA max.

ZBH (Quadrature): 250 mA max. current per output. Incremental - two square waves in quadrature with Channel A leading Channel B for clockwise rotation. (Quad. Phase relationship is 90° ±22.5 electrical degrees)

Note: NPN Transistor outputs have 1.5 KΩ load resistors returned to supply for internal feed back purposes. This does not interfere with the ability to use these outputs as conventional "Open-Collector" outputs as long as the supply voltage for the ZB is supplied by the indicator or control receiving its output signal. The ZB's internal load resistor also allows the output to be used as a current source, however, load current must be limited to 1 mA max.

3. MAXIMUM FREQUENCY:

Single Channel: 20 KHz

Quadrature: 20 KHz

PPR available up to 1270 for both single channel and quadrature.

MECHANICAL SPECIFICATIONS

1. MAXIMUM SHAFT SPEED: 6000 RPM

2. SHAFT DIAMETER: 0.375" (9.5 mm)

3. RADIAL SHAFT LOAD: 40 lbs. operating (18 kg)

4. AXIAL SHAFT LOAD: 30 lbs operating (13.6 kg)

5. STARTING TORQUE:

ZBG & ZBH: 0.38 oz-in (2.68 N-mm)

ZHG: 3 oz-in (21.18 N-mm)

6. MOMENT OF INERTIA: 6.5 x 10⁻⁶ oz-in-sec²

7. CONNECTIONS: 6-pin MS style or 8-Pin M12 connector. (Male) Mating connector and cable assembly sod separately. For wiring configuration, see Cable Connections. For Ordering Information, see Accessories.

8. HOUSING: Black non-corrosive finished 6063-T6 aluminum.

9. BEARINGS: ABEC3 double sealed ball bearings

10. WEIGHT:

ZBG & ZBH: 10 oz (283.5 g)

ZHG: 3.8 lbs (1.72 Kg)

ENVIRONMENTAL SPECIFICATIONS

1. OPERATING TEMPERATURE: 0 ° to 100 °C (See supply voltage)

2. STORAGE TEMPERATURE: -25°C to +85°C

3. HUMIDITY: 98% RH non-condensing

4. VIBRATION: 10 g @ 58 to 500 Hz

5. SHOCK: 50 g @ 11 msec duration

Cable Connections

The tables below list the pin connections from the ZBG and ZHG single channel and ZBH quadrature encoder to the optional CCARPG or CCM cable.

FUNCTION	6-PIN MS CONN	M12 CONN	CABLE WIRE COLOR
+VDC	A	1	RED
COMMON	B	2	BLACK
DATA A	C	3	WHITE
DATA B if appl. (quad)	D	4	GREEN
NO CONNECTION	E	5	—

ORDERING INFORMATION

MODEL NO.	DESCRIPTION	PPR*	PART NUMBER	
ZHG	Single Channel - Heavy Duty Rotary Pulse Generator * For Dual Channel contact factory	600	ZHG06004	
		1000	ZHG10004	
		1200	ZHG12004	
ZBG	Single Channel General Service 6-Pin MS Connector	60	ZBG00602	
		100	ZBG01002	
		600	ZBG06002	
		1000	ZBG10002	
		1200	ZBG12002	
		Single Channel General Service M12 Connector	100	ZBG01003
600	ZBG06003			
ZBH	Dual Channel General Service 6-Pin MS Connector	10	ZBH00102	
		12	ZBH00122	
		100	ZBH01002	
		120	ZBH01202	
		500	ZBH05002	
		600	ZBH06002	
		Dual Channel General Service M12 Connector	100	ZBH01003
			600	ZBH06003

Note: Only factory stocked part numbers are listed. Consult factory for part number and availability of other PPR and output configurations.

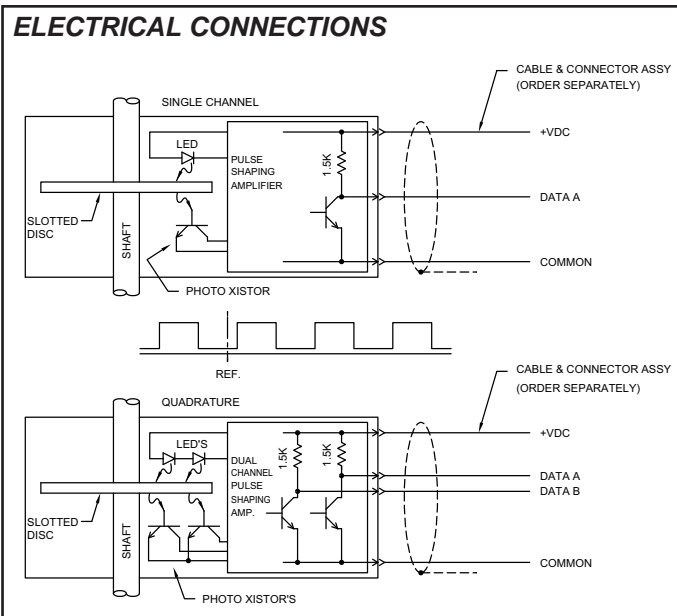

ACCESSORIES

MODEL NO.	DESCRIPTION	PART NUMBER
RPGFC	Flexible Coupling (1" Length) 0.250"-0.375"	RPGFC002
	Flexible Coupling (1" Length) 0.375"-0.375"	RPGFC003
	Flexible Coupling (1" Length) 0.375"-0.500"	RPGFC004
	Flexible Coupling (1" Length) 0.375"-6 mm	RPGFC006
Mating 6-Pin MS Connector		CCARPG00
6-Pin MS Connector w/10 feet 22 AWG 4-conductor w/drain		CCARPG01
6-Pin MS Connector w/25 feet 22 AWG 4-conductor w/drain		CCARPG25
6-Pin MS Connector w/50 feet 22 AWG 4-conductor w/drain		CCARPG50
M12 Connector w/4 Meter 24 AWG 5-conductor w/drain		CCM12894
M12 Connector w/10 Meter 24 AWG 5-conductor w/drain		CCM12890

LENGTH SENSOR CONVERSION BRACKET (P/N LSCB1000)

ADAPTS ZBG and ZBH ROTARY PULSE GENERATOR TO LENGTH MEASUREMENT

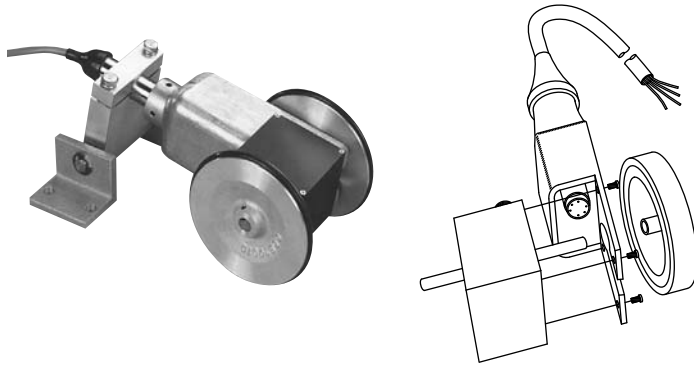

The tubular arm length of this bracket, related to the wheel axis center-line of the ZBG or ZBH is 6.8" similar to the length sensors. The 10' long, 4-wire, shielded cable (included with conversion bracket) has the same color coding as described for the ZBG and ZBH cable P/N CCARPG01. Screws for mounting the conversion bracket are included.

ORDERING INFORMATION

MODEL NO.	DESCRIPTION	PART NUMBER
LSCB	Length Sensor Conversion Bracket for ZBG and ZBH	LSCB1000
	Length Sensor Conversion Bracket for ZBG and ZBH (Special Length)	LSCB1099
--	Hinge Clamp Assembly for Length Sensors & Conversion Bracket (Above)	LSAHC001

DESCRIPTION

This conversion bracket allows the customer to assemble a custom length sensor by purchasing the following items separately.

1. Length Sensor Conversion Bracket (P/N LSCB1000)
2. ZBG or ZBH with appropriate PPR and Single Channel or Quadrature Output.
3. One or two measuring wheels. Install OF & OK measuring wheels with set screw hub facing ZBG shaft (as shown). Apply thread locking material to wheel set screw threads during installation to ZBG or ZBH shaft.
4. Hinge Clamp Assembly (P/N LSAHC001)

Note: To complete installation, insure guards, shields or other devices are in place to protect personnel from rotating equipment.

LENGTH SENSOR MEASUREMENT ACCURACY

Factors which affect measurement accuracy include Measuring Wheel accuracy and wear, and material conditions. Ideally, materials which are hard, thin and strong provide good readings, conversely, soft, thick and elastic materials can present problems in obtaining true readings. The great majority of these situations, where this effect is consistent, can be compensated for by applying a multiplier to the quadrature output pulse train so as to obtain a corrected measurement. Counter or Rate Indicators with "input scaling" can compensate for Measuring Wheel wear and material elastic and compliance errors. In addition, English/Metric conversions may also be accomplished (See RLC catalog for more information).

LENGTH SENSOR ACCESSORIES

SEPARATE LENGTH MEASURING WHEELS - DIMENSIONS In Inches (mm)

WHEEL CODE	OR	WHEEL CODE	OF	WHEEL CODE	OK
	<p>FOR USE ON: Metal, paper, foil, film and hard plastics. Line contact on material being measured, convenient when available measuring track is narrow or for measuring on end of roller beside passing material.</p> <p>Max. Speed: 600 RPM</p>	<p>FOR USE ON: Soft, smooth materials such as soft paper, matting, cardboard, fine weave textiles. Broad wheel tread minimizes contact pressure and tan polyurethane tread minimizes marking.</p> <p>Max. Speed: 600 RPM</p> <p>Balanced version of 1ft. circumference available. Balanced to ANSI S2.19-1989 Quality Grade 6.3 @ 3000 RPM.</p>	<p>FOR USE ON: Rubber, coarse weave fabrics, rough wood surfaces, foam, insulation.</p> <p>Max. Speed: 600 RPM</p> <p>Balanced version of 1ft. circumference available. Balanced to ANSI S2.19-1989 Quality Grade 6.3 @ 3000 RPM.</p>		

SELECTING APPROPRIATE WHEEL SIZE & PPR (Pulses Per Rev.) OF ROTARY PULSE GENERATOR

When the desired output of a length sensor and wheel combination is either in feet or inch units, selection of the proper combination is relatively straight forward. For example, with a 1-foot wheel circumference, a 1 PPR Rotary Pulse Generator will deliver 1 pulse/ft, 12 PPR would deliver 12 pulses/ft (1 pulse/inch); 100 PPR would yield 100 pulses/ft; and 120 PPR would permit measuring to 1/10th of an inch (1/120th of a foot).

WHEELS & REPLACEMENT TIRES FOR CODE OR WHEELS

ORDERING INFORMATION

WHEEL CODE	CIRCUMFERENCE	TOLERANCE	PART NUMBER
OR	1 foot (1/3 yd)	±0.40%	WF1000OR
	1/3 meter	±0.40%	WM0333OR
	4/10ths yard	±0.40%	WY0400OR
	4/10ths meter	±0.40%	WM0400OR
OF	1 foot (1/3 yd)	±0.35%	WF1000OF
	1/3 meter	±0.30%	WM0333OF
	4/10ths yard	±0.30%	WY0400OF
	4/10ths meter	±0.30%	WM0400OF
BF (Balanced)	1 foot (1/3 yd)	±0.40%	WF1000BF

WHEEL CODE	CIRCUMFERENCE	TOLERANCE	PART NUMBER
OK	1 foot (1/3 yd)	±0.35%	WF1000OK
	1/3 meter	±0.30%	WM0333OK
	4/10ths yard	±0.30%	WY0400OK
	4/10ths meter	±0.30%	WM0400OK
BK (Balanced)	1 foot (1/3 yd)	±0.35%	WF1000BK
Replacement Tires for OR Wheels	1 foot (1/3 yd)		TORF1000
	1/3 meter		TORM0333
	4/10ths yard		TORY0400
	4/10ths meter		TORM0400

Note: After installation of measuring wheels, ensure guards, shields or other devices are in place to protect personnel from rotating equipment.

MODEL LSAHC - LENGTH SENSOR HINGE CLAMP ASSEMBLY

The Length Sensor Hinge Clamp Assembly provides an easy method for attachment and mounting of the Length Sensors and LSCB1 Conversion Bracket. The removable top on the solid zinc LSAHC mounting block allows quick installation of the Length Sensor handle tube and provides secure clamping retention. The mounting block pivots freely in zinc right angle brackets to allow mounting the assembly via clearance holes for 1/4" dia. bolts.

The lock washers must be used as indicated (between the bolt head and the top clamp piece). Assemble the top clamp piece as follows.

1. Tighten both bolts so that the top clamp half draws down evenly on the sensor tube.
2. Tighten the bolts until both lock washers are flat.
3. Then turn each bolt an additional 1/2 to 3/4 turn.

DIMENSIONS In inches (mm)

FRONT VIEW

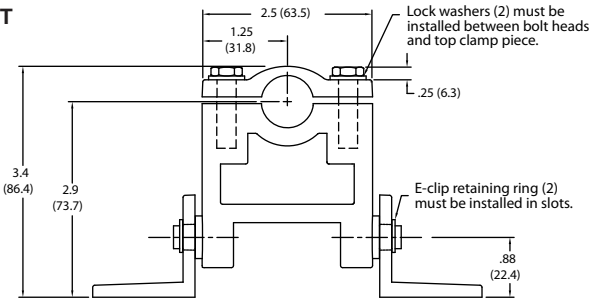

TOP VIEW

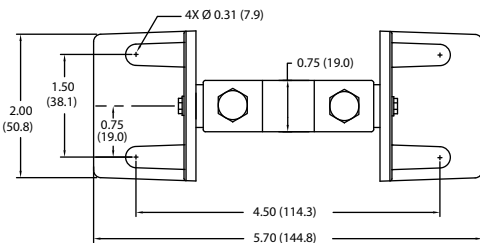

ORDERING INFORMATION

MODEL NO.	DESCRIPTION	PART NUMBER
LSAHC	Length Sensor Hinge Clamp Assembly	LSAHC001

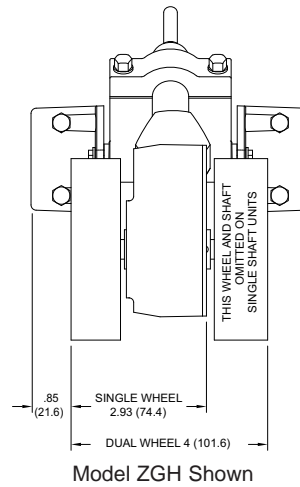

CAUTION: Downward tension on signal cable can cause wheel(s) to lift. Make sure cable is clamped to machine frame near encoder and allow slack.

NOTE: The weight at the Length Sensor unit provides sufficient traction for accurate operation when mounted as shown, with arm angle from horizontal not exceeding ±30°, and with hinge clamp toward the far extreme of the extension arm.

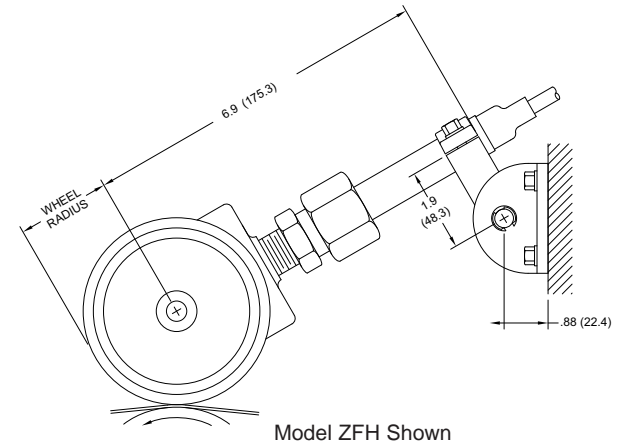

Length Sensors should be mounted so measuring wheel(s) contact ribbon, strip or web as it passes over a roller. As an alternative, wheel(s) can be driven by roller surface next to material being measured.

Red Lion Controls
Headquarters
20 Willow Springs Circle
York PA 17406
Tel +1 (717) 767-6511
Fax +1 (717) 764-0839

Red Lion Controls
Europe
Printerweg 10
NL - 3821 AD Amersfoort
Tel +31 (0) 334 723 225
Fax +31 (0) 334 893 793

Red Lion Controls
India
54, Vishvas Tenement
GST Road, New Ranip,
Ahmedabad-382480 Gujarat, India
Tel +91 987 954 0503
Fax +91 79 275 31 350

Red Lion Controls
China
Unit 101, XinAn Plaza
Building 13, No.99 Tianzhou Road
ShangHai, P.R. China 200223
Tel +86 21 6113-3688
Fax +86 21 6113-3683